

Especificaciones

| | | Salida típica de eje | | | | Intensidad de entrada | |
|---------------|------|----------------------|----------------|---------------|-----------------|-----------------------|-------------------|
| Tensión de | Tipo | $P_{N,M}$ [kW] | $P_{N,M}$ [HP] | I_{INV} [A] | I_{MAX} (60s) | $I_{L,N}$ [A] | $I_{L,MAX}$ (60s) |
| 1 x 220-240 V | 2803 | 0.37 | 0.5 | 2.2 | 3.5 | 5.9 | 9.4 |
| | 2805 | 0.55 | 0.75 | 3.2 | 5.1 | 8.3 | 13.3 |
| | 2807 | 0.75 | 0.75 | 4.2 | 6.7 | 10.6 | 16.7 |
| | 2811 | 1.1 | 1.5 | 6.0 | 9.6 | 14.5 | 23.2 |
| | 2815 | 1.5 | 2.0 | 6.8 | 10.8 | 15.2 | 24.3 |
| | 2822 | 2.2 | 3.0 | 9.6 | 10.6* | 22.0 | 24.3 |
| | 2840 | 3.7 | 5.0 | 16.0 | 17.6* | 31.0 | 34.5 |
| 3 x 200-240 V | 2803 | 0.37 | 0.5 | 2.2 | 3.5 | 2.9 | 4.6 |
| | 2805 | 0.55 | 0.75 | 3.2 | 5.1 | 4.0 | 6.4 |
| | 2807 | 0.75 | 1.0 | 4.2 | 6.7 | 5.1 | 8.2 |
| | 2811 | 1.1 | 1.5 | 6.0 | 9.6 | 7.0 | 11.2 |
| | 2815 | 1.5 | 2.0 | 6.8 | 10.8 | 7.6 | 12.2 |
| | 2822 | 2.2 | 3.0 | 9.6 | 15.3 | 8.8 | 14.1 |
| | 2840 | 3.7 | 5.0 | 16.0 | 25.6 | 14.7 | 23.5 |
| 3 x 380-480 V | 2805 | 0.55 | 0.75 | 1.7 | 2.7 | 1.6 | 2.6 |
| | 2807 | 0.75 | 1.0 | 2.1 | 3.3 | 1.9 | 3.0 |
| | 2811 | 1.1 | 1.5 | 3.0 | 4.8 | 2.6 | 4.2 |
| | 2815 | 1.5 | 2.0 | 3.7 | 5.9 | 3.2 | 5.1 |
| | 2822 | 2.2 | 3.0 | 5.2 | 8.3 | 4.7 | 7.5 |
| | 2830 | 3.0 | 4.0 | 7.0 | 11.2 | 6.1 | 9.8 |
| | 2840 | 4.0 | 5.0 | 9.1 | 14.5 | 8.1 | 13.0 |
| | 2855 | 5.5 | 7.5 | 12 | 19.2 | 10.6 | 17.0 |
| | 2875 | 7.5 | 10.0 | 16 | 25.6 | 14.9 | 23.8 |
| | 2880 | 11.0 | 15.0 | 24 | 38.4 | 24.0 | 38.4 |
| | 2881 | 15.0 | 20.0 | 32 | 51.2 | 32.0 | 51.2 |
| 2882 | 18.5 | 25.0 | 37.5 | 60.0 | 37.5 | 60 | |

* disponible sólo el 110% de par

Dimensiones (mm):

Altura

| | | | | |
|----|-----|-------|-------|-----|
| A: | 200 | 267.5 | 267.5 | 505 |
| a: | 191 | 257 | 257 | 490 |

Anchura

| | | | | |
|----|----|----|-----|-----|
| B: | 75 | 90 | 140 | 200 |
| b: | 60 | 70 | 120 | 120 |

Profundidad

| | | | | |
|----|-----|-----|-----|-----|
| C: | 168 | 168 | 168 | 244 |
|----|-----|-----|-----|-----|

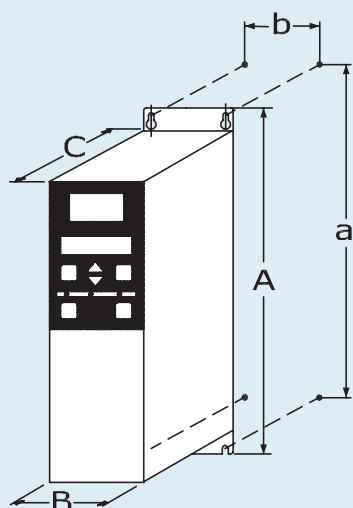

Conexiones de entrada y salida

